

Bulletin DB-C106AA05

Type V2-CA  
**Aluminum  
Vertical Break Switch**

7.2 - 69 kV  
600 - 2000 A.

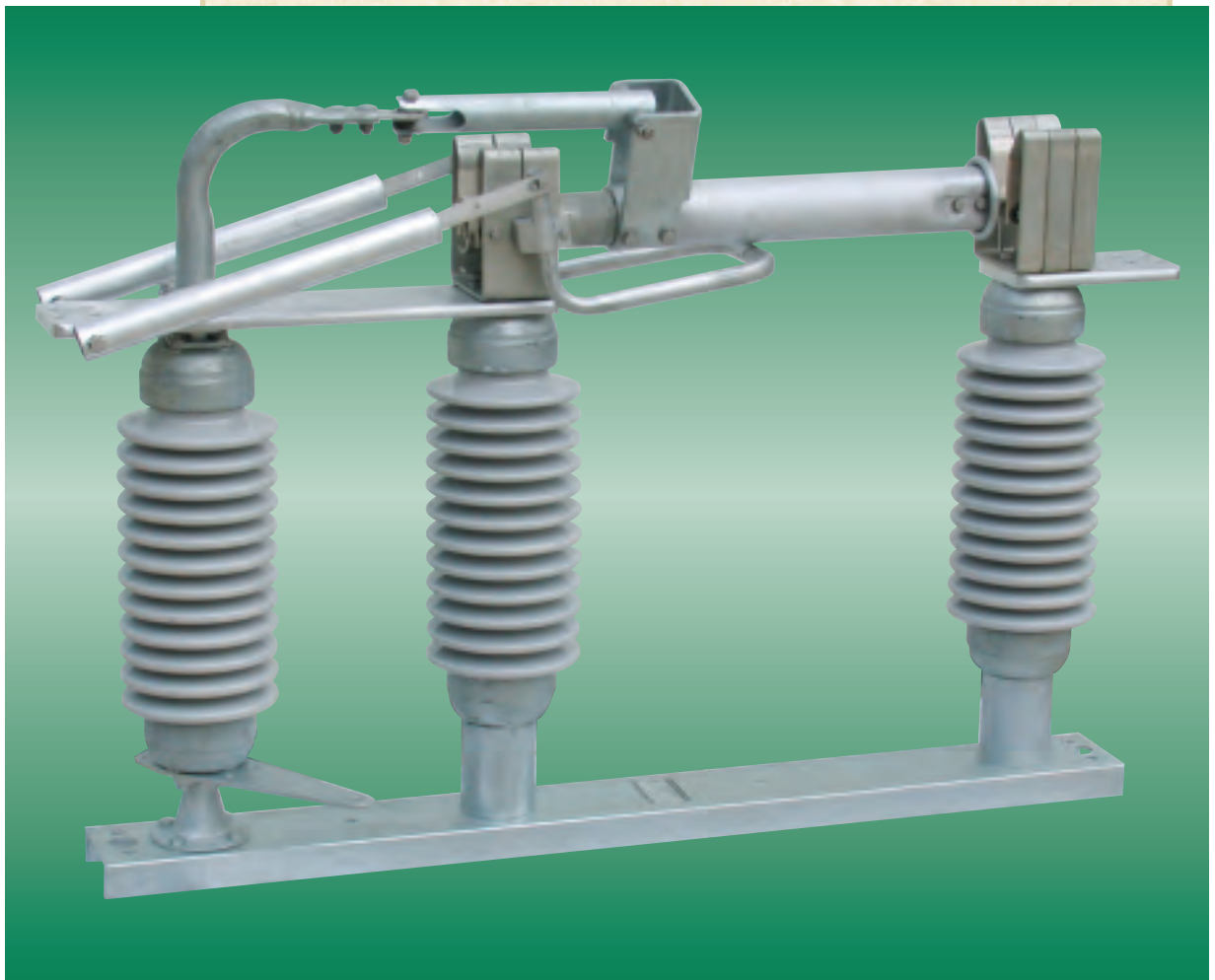

***CP*** **CLEAVELAND/PRICE INC.**

14000 Rt. 993, Trafford, PA 15085 (724) 864-4177

FAX (724) 864-9040

E-mail: [sales@cleavelandprice.com](mailto:sales@cleavelandprice.com)

# Designed for Simplicity

## V2-CA APPLICATION

The **Cleveland/Price V2-CA** is a three pole, group operated, aluminum vertical break switch for installation in substation or distribution line locations. The switch can be mounted in the horizontal-upright, vertical, or horizontal-underhung position. The V2-CA is suitable for use in a variety of applications including line disconnecting and sectionalizing, circuit breaker by-pass and isolation, and transformer isolation.

Arc horns or quick break whips are supplied when small amounts of transformer magnetizing currents and line charging currents must be interrupted.

Accessories and options needed to adapt the switch to a customer's particular requirements are available. The V2-CA may be manually operated by use of a swing handle or wormgear mechanism or electrically operated by use of a type TP-C2 motor operator.

The V2-CA is designed to meet NEMA and IEEE Standards and the rating requirements of applicable IEC Standards.

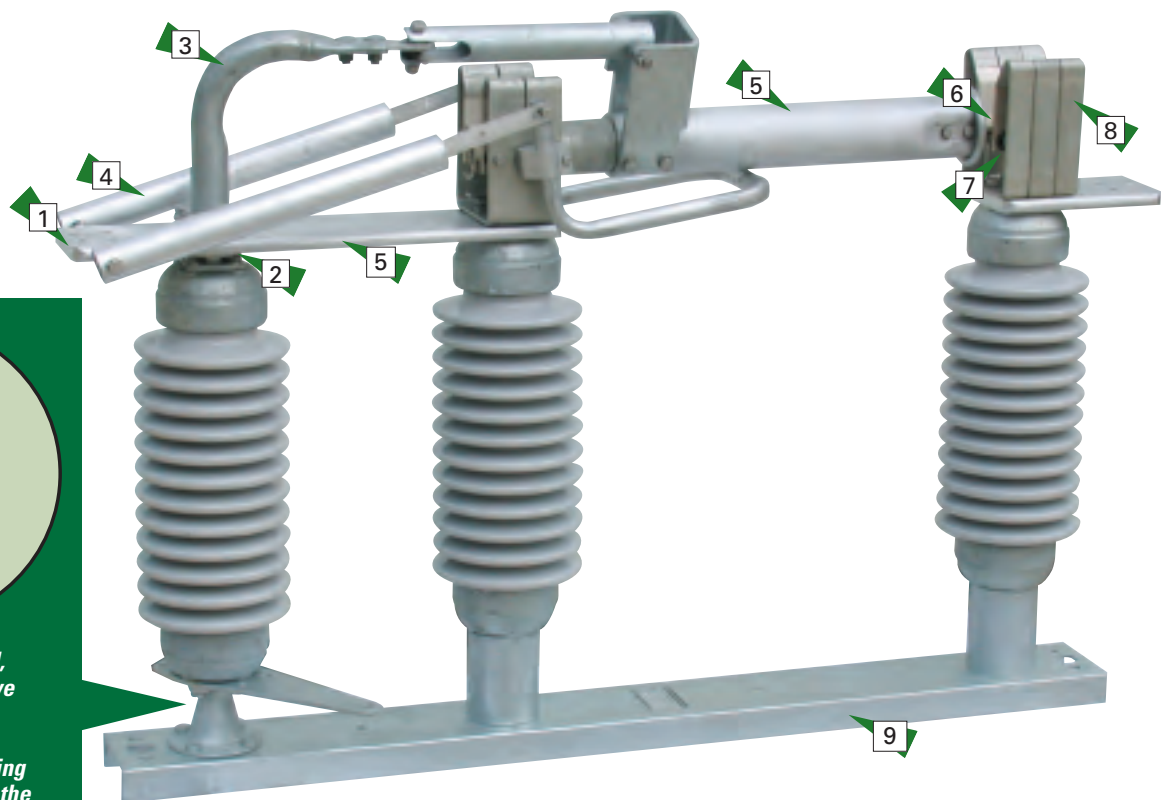

*Permanently lubricated, maintenance-free sleeve bearing.*

*Rotating insulator bearing does not extend below the housing base to interfere with the mounting structure.*

- 1** ▶ Unbreakable, non-cast aluminum terminal pads with NEMA standard hole pattern
- 2** ▶ Fully insulated journal bearing
- 3** ▶ Unbreakable, non-cast operating crank
- 4** ▶ Stainless steel counterbalance springs that are insulated from the current path
- 5** ▶ Corrosion resistant, high conductivity aluminum current-carrying parts
- 6** ▶ Silver-to-silver contacts at hinge and jaw
- 7** ▶ Stainless steel contact springs insulated from the current path
- 8** ▶ Hard-drawn, high conductivity tin-plated copper contact fingers at hinge and jaw
- 9** ▶ Hot-dipped galvanized steel base

# Engineered for Performance

## THE CLEVELAND/PRICE APPROACH

Cleveland/Price has a very basic approach to design . . . keep it simple. It is an approach that is employed from material selection to mechanical design.

The Cleveland/Price V2-CA disconnect switch current carrying parts are manufactured from corrosion resistant high strength, high conductivity aluminum. All switches are of non-cast design for superior dependability of parts. Switch performance is not troubled by flaws that could occur in the casting process.

Contacts are designed to take advantage of electromagnetic forces by using a reverse loop configuration at both the hinge and jaw of the switch. Current transfer points are kept to a minimum.

**PROBLEM:** When the switch blade on a conventional switch rotates in the break-jaw to the final blade position, it does not consistently stop at the point of optimum contact pressure. The resulting inadequate contact pressure may cause contact pitting and burning.

Many switches use a stop on the rotating insulator to try to set proper blade position. This type of stop is too remote from the blade to accurately control the blade motion because of the cumulative play in the linkage joints. Variation in the speed of the operator can actually affect the amount of blade turnover.

**SOLUTION:** On the Cleveland/Price V2-CA, the blade stop is on the blade itself instead of an intermediate linkage point (the rotating insulator). The V2-CA stop location assures that blade rotation in the break-jaw will accurately and consistently stop at the point of maximum contact pressure.

The cutaway view shows how the unique Cleveland/Price turnover stop allows the blade to rotate until the slot in the blade engages with the hinge pin. This sets the proper turnover angle.

The stop angle is factory-machined for built-in accuracy. No matter how fast or slow the blade moves, it doesn't stop moving until it has fully turned over.

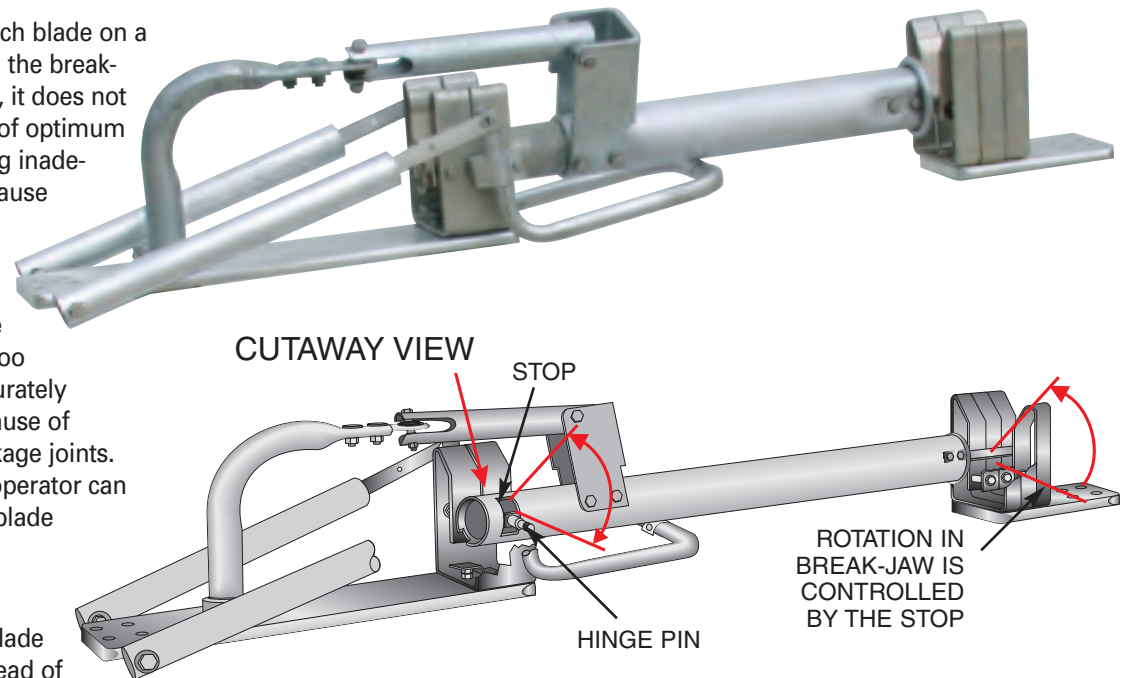

## CLEVELAND/PRICE FEATURES FOR OUTSTANDING PERFORMANCE AND LONG LIFE

The V2-CA is made of the finest materials for dependable, trouble-free service. Knowledge gained from maintaining switches in the field for over 60 years has played a major part in refining the V2-CA. Significant design features include:

- Total non-cast aluminum and steel construction resulting in the superior dependability of parts
- Live parts constructed from extruded aluminum and hard-drawn, high conductivity copper producing stronger, more conductive components than parts made of cast materials
- Silver-to-silver moving contacts
- Open construction of the hinge and smooth non-cast surfaces throughout, enabling the V2-CA to break ice with amazing ease
- Wiping action on both the break-jaw and hinge keeps contacts clean for years of reliable service
- Visible hinge contacts allow easy verification of contact condition without disassembly
- Reverse loop electromagnetic design at hinge and break-jaw on all ratings gives outstanding performance under fault conditions

# Exclusive Cleaveland/Price V2-CA Features

The Cleaveland/Price V2-CA is an advanced design vertical break switch with features of genuine value to the customer. It incorporates several patented improvements:

1. Positive blade turnover stop is the key to consistent and complete contact pressure to prevent contact burning.
2. Insulating journal bearing prevents current flow through the live operating linkage.
3. Floating break-jaw contacts allow blade and break-jaw fingers to move together under short circuit and seismic duty to outperform conventional contact systems.

## UNIQUE BREAK-JAW DESIGN

Short circuit tests prove that the V2-CA break-jaw is superior to conventional break-jaws. On the V2-CA, phase-to-phase electromagnetic forces that pull the blade side-to-side do not decrease the contact pressure since the fingers of the jaw are joined together to create a floating spring system that moves with the blade. Maximum contact pressure is maintained on all contact surfaces during short circuit and seismic events.

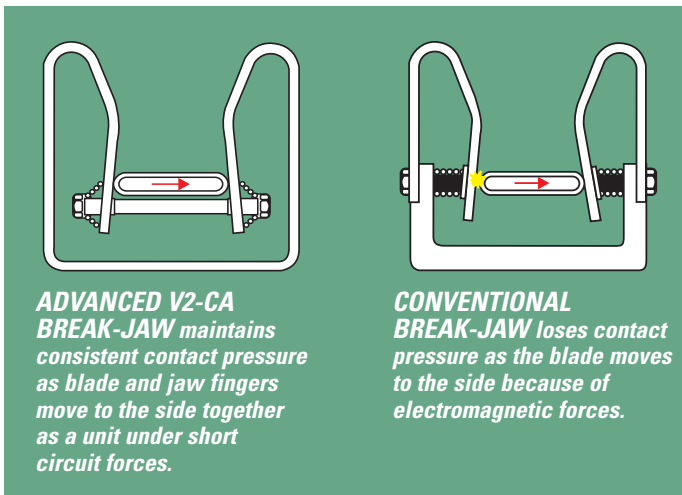

ANSI standards require that a switch pass the rated short circuit test only once. Standards also allow live parts to be changed for each test. The V2-CA contact system gives greater confidence in short circuit performance as demonstrated by 12 consecutive test shots on a 2000 amperes switch using the same set of live parts.

## FEATURE FOR EASY ADJUSTMENT

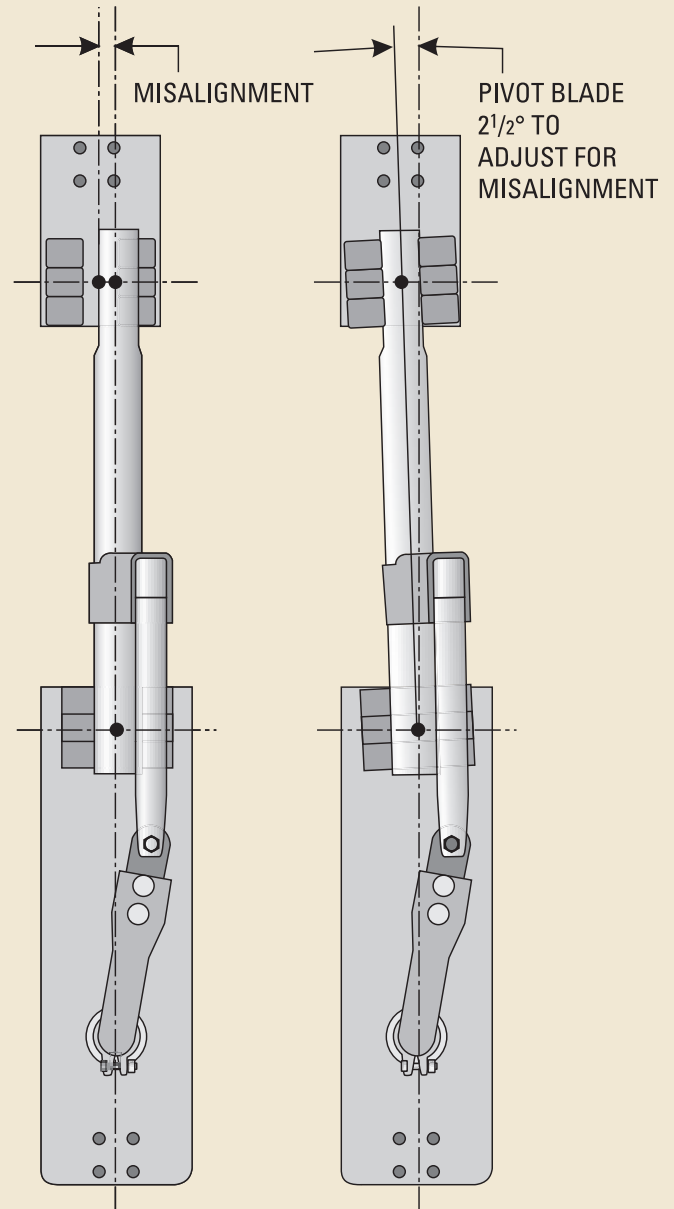

## PIVOTING HINGE

During installation, the blade may be misaligned with the break-jaw, requiring adjustment of the insulators. However, it is often easier to pivot the blade to attain alignment with the jaw contact. This is particularly true when bus and ground blades have been installed at the jaw terminal and the blades are not perfectly adjusted. By loosening the bolts that attach the hinge and jaw to the stationary insulators and closing the switch, the blade and jaw automatically seat themselves in the proper alignment. Retighten the bolts and the adjustment is complete without having to realign the ground switch or bus.



# Type V2-CA Aluminum Vertical Break Switch

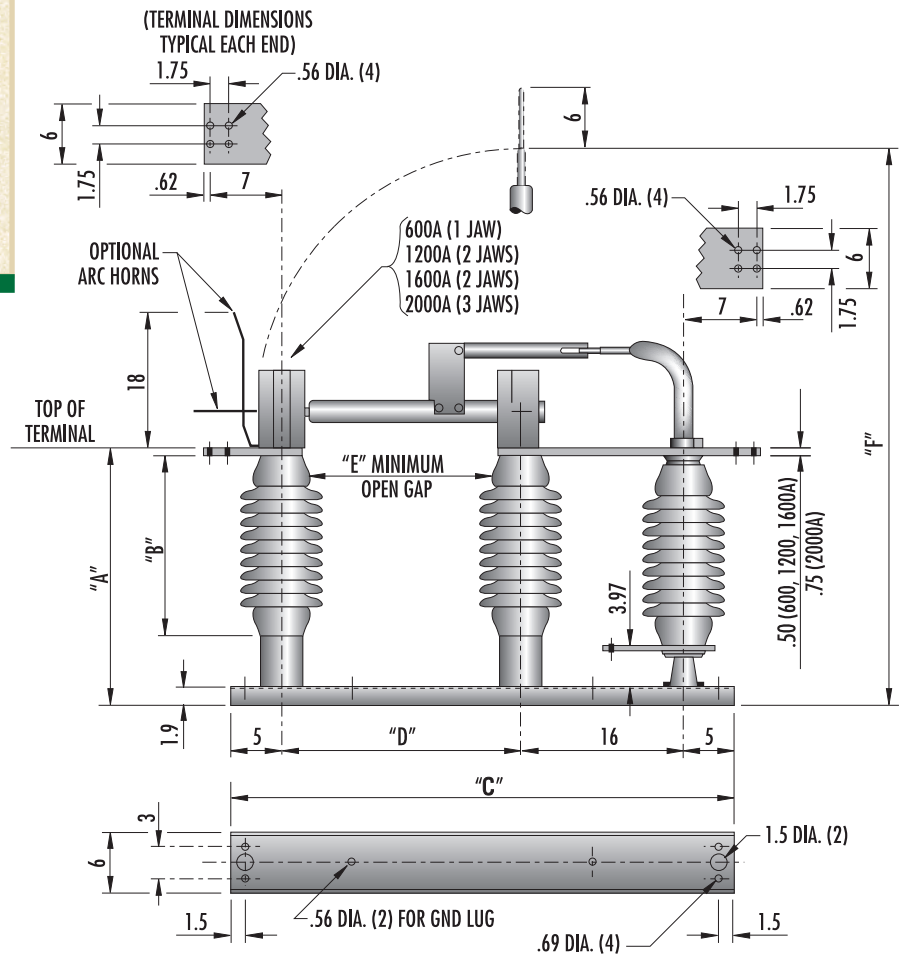

Nom. kV	Max. kV	KV BIL	Ins. TR#	Amp.	Mom. kA	Switch Style Number	"A"	"B"	"C"	"D"	"E"	"F"	Wt./ Pole
7.2	8.3	95	202	600	40	C06A032G01	14.93	7.5	41	15	7	34.43	145
				1200	61	C06A032G02							151
				1600	70	C06A032G03							153
				2000	100	C06A032G04							165
14.4	15.5	110	205	600	40	C06A032G05	17.43	10	41	15	10	36.93	163
				1200	61	C06A032G06							169
				1600	70	C06A032G07							171
				2000	100	C06A032G08							183
23	27	150	208	600	40	C06A032G09	21.43	14	50	24	12	49.93	193
				1200	61	C06A032G10							200
				1600	70	C06A032G11							203
				2000	100	C06A032G12							217
34.5	38	200	210	600	40	C06A032G13	25.43	18	50	24	18	53.93	227
				1200	61	C06A032G14							235
				1600	70	C06A032G15							238
				2000	100	C06A032G16							251
46	48.3	250	214	600	40	C06A032G17	29.43	22	56	30	22	63.93	283
				1200	61	C06A032G18							291
				1600	70	C06A032G19*							295
				2000	100	C06A032G20*							309
69	72.5	350	216	600	40	C06A032G21	37.43	30	66	40	32	81.93	396
				1200	61	C06A032G22*							405
				1600	70	C06A032G23*							410
				2000	100	C06A032G24*							426

\* Counterbalanced ratings

# Operators/Accessories

## Ordering Information

### Furnish:

- Switch type
- Voltage
- Amperage
- Momentary rating
- BIL level
- Mounting position
- Operator type
- Accessories required

## Available Accessories

- Arc horns
- Auxiliary switch
- Braidless ground contact
- Electrical interlock
- Extended operator
- Ground blades
- Ground blade mechanical interlock
- Insulated vertical pipe
- Interrupting device
- Key interlock
- Mounting hardware
- Operator grounding platform
- Outriggers
- Quick break whips
- Spill gaps
- Terminal connectors

*This brochure describes our standard product and does not show variations in design that may be available. Contact the factory for additional details.*

*Cleveland/Price reserves the right to make changes or improvements to the product shown in this brochure without notice or obligation.*



Swing Handle Operator



Handcrank Operator



Motor Operator Type TP-C2

### Standard Operator Features

- Swing handle operator
- Padlock provision in both the open and closed positions
- Ground strap for vertical operating pipe
- Adjustable stops
- Clamp-on open/closed indicators
- Self-lubricating, maintenance-free outboard bearing
- 1-1/2" IPS galvanized steel vertical operating pipe

 **CLEVELAND/PRICE INC.**

14000 Route 993 • Trafford • PA 15085  
Telephone (724) 864-4177 • FAX (724) 864-9040  
website: [www.clevelandprice.com](http://www.clevelandprice.com)