

CHAIN DRIVE OPERATOR PADLOCKING AND KEY INTERLOCK MOUNTING PROVISIONS IN OPEN AND CLOSED POSITIONS

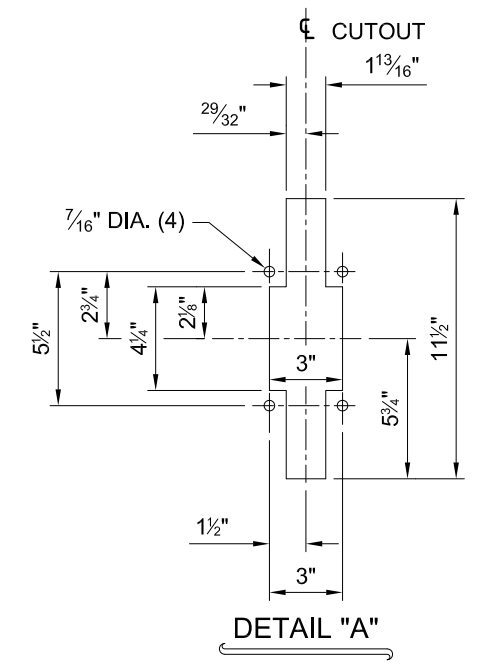
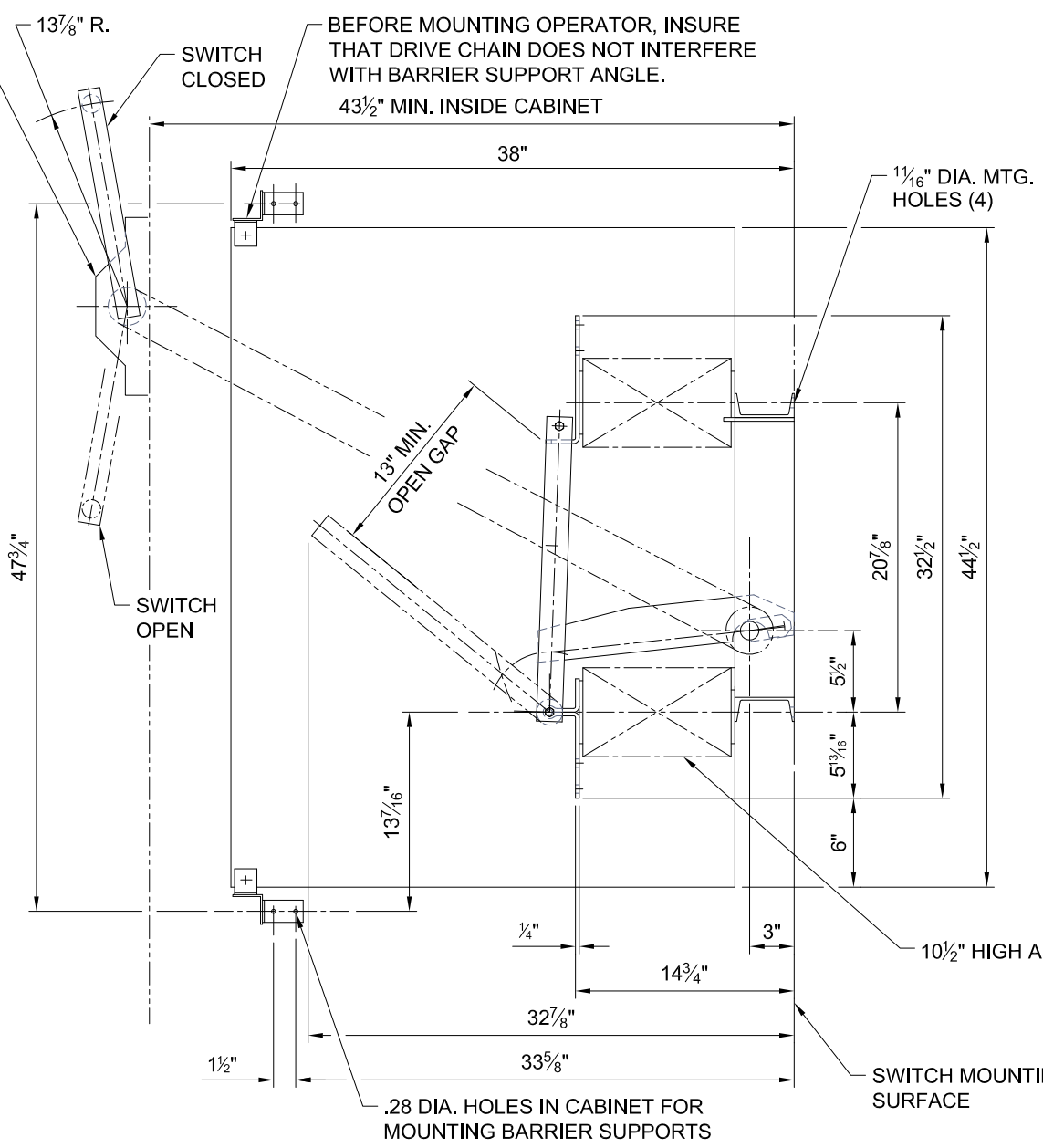
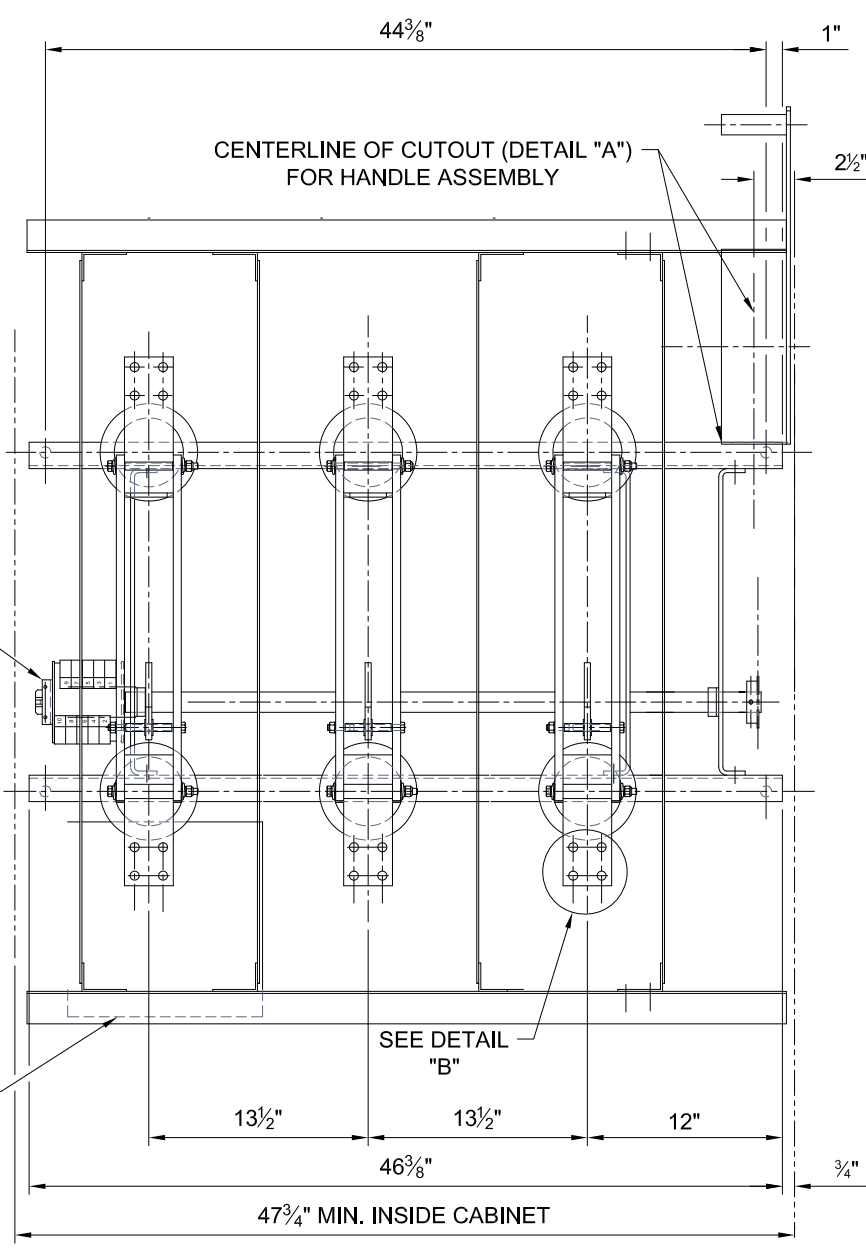

AUXILIARY SWITCH (IF REQUIRED)

JUNCTION BOX FOR AUXILIARY SWITCH WIRING. BOX TO BE MOUNTED TO SWITCH BASE.

SEE DETAIL "B"

BEFORE MOUNTING OPERATOR, INSURE THAT DRIVE CHAIN DOES NOT INTERFERE WITH BARRIER SUPPORT ANGLE.  
43 1/2" MIN. INSIDE CABINET

.28 DIA. HOLES IN CABINET FOR MOUNTING BARRIER SUPPORTS

SWITCH MOUNTING SURFACE

REVISION	
----------	--

REV	-				
CODE	A00				
	 <b>Cleaveland/Price Inc.</b> 14000 Route 993 : Trafford, PA 15085	DATE	SHEET	SCALE	
	DRAWN	CHECKED	DATE	SHEET	SCALE
	MN	AGM	01/13/2014	1 OF 1	PROPORTIONAL
LCG-C OUTLINE 34.5kV 150kV BIL 1200A 61kA MOM. with CHAIN DRIVE OPERATOR					DWG NO. <b>C00B034</b>